

# COUPLERTEC™

**ELECTRONIC RUSTPROOFING**

*The World's Best PROTECTION From RUST!*



## PRODUCT INSTALLATION GUIDE



**MODEL: CT2**

**PRODUCT CODE: CT2SFK**

Standard System 12V Input, Two Capacitive Couplers

## KIT CONTENTS

ITEM	QTY	ITEM	QTY	ITEM	QTY
Couplertec Module	1	Self - Tapping Screw	1	6mm Hex Nut	2
Capacitive Coupler	2	Heat Shrink Connector	3	Alcohol Cleaning Pad	3
Fuse Holder	1	Heat Shrink Ring Terminal	1	Split Loom 3m	1
Fuse (2Amp)	1	Small Ring Terminal	1	Cable Ties	10



When installing the Couplertec Electronic Rustproofing System, you will need:

## TOOLS REQUIRED

- Wire Stripper
- Side Cutter
- Heat Gun or Gas Torch
- Crimping Tool
- Shifting Spanner
- Multimeter

**PLEASE READ THE FOLLOWING FITTING INSTRUCTIONS CAREFULLY BEFORE PROCEEDING TO INSTALL THE COUPLERTEC ELECTRONIC RUSTPROOFING SYSTEM.**

For technical support please contact one of our Couplertec Technical Service Representatives during the following times:  
Monday – Friday 8.30am – 4.30pm EST. Australia

Calling From Within Australia: 1800 66 78 78 | International Calls: +61 7 5522 0200

### STEP 1

#### Select a site to locate the Couplertec Module

The Module should be mounted within the engine bay as high as possible on either the firewall or front guard, preferably on the same side as the vehicles main/start battery. The Module can be mounted either horizontally or vertically. Try and locate the Module in a site that will not interfere with normal vehicle repair or maintenance, and preferably a site where the two LED indicators will be visible.

### STEP 2

#### Select a site to ground/earth the Modules Green wire

The Green Wire from the Module must be grounded/earthed to the metal body of the vehicle at a minimum distance of 50cm away from the nearest Capacitive Coupler location.

### STEP 3

#### Selecting sites to locate the Capacitive Couplers

- Locate 2 x Capacitive Couplers within the engine bay, one on the left side and one on the right side as high as possible on either the firewall, inner guard or wheel arch.

#### IMPORTANT INFORMATION:

The Capacitive Coupler site must be

- A relatively flat painted metal surface (no contoured surfaces or indentations)
- Large enough to accommodate the entire surface area of the Capacitive Coupler
- Free of holes
- Free of joins in the metal work.
- Free of spot welds, welding slag/spikes
- Well painted with no scratches (if in doubt, lightly sand and apply two coats of quick dry enamel paint to the area).

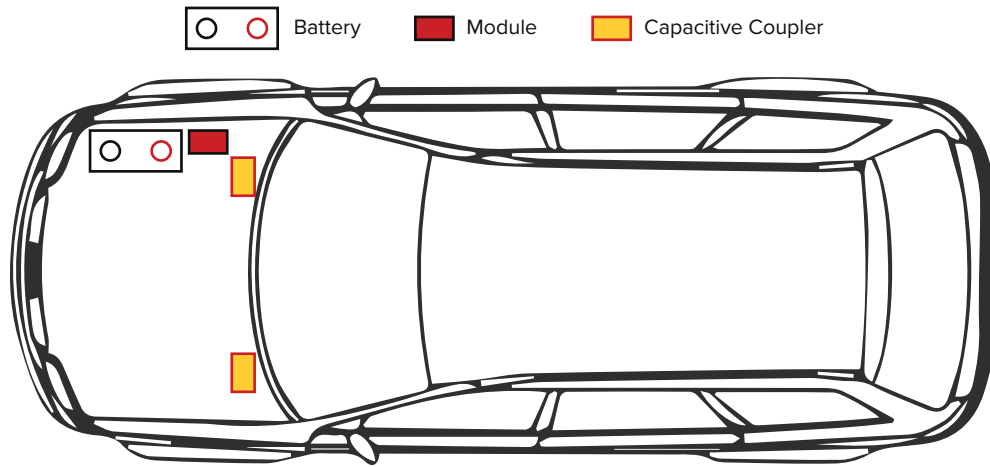

**FIGURE: 1**  
Example diagram of a vehicle installation

## STEP 4

### Fitting the Module

- Thoroughly clean the site where the CouplerTec Module is to be located using the alcohol cleaning pad. Remove any oil, wax or dirt. For extremely dirty sites, use white spirits or similar with a rag to clean the site, followed by the use of the alcohol cleaning pad.
- Once the site is clean and dry, peel off the backing paper from the back of the CouplerTec Module and press the Module firmly against the prepared site.
- Route the Green Wire from the Module towards the ground/earth location. Cut the Green Wire to length (the wire can be extended if necessary), strip the end of the Green Wire and crimp on the Small Ring Terminal. Use the self tapping screw to secure the Ring Terminal to the body of the vehicle.
- Attach the pre-wired half of the fuse holder (ring terminal) directly to the positive battery terminal on the vehicles main start battery. Do not undo the nut on the battery terminal unless absolutely necessary, if possible, use the supplied 6mm hex nut to screw onto the thread of the battery terminal and tighten up to the existing nut. Neatly route the Red Wire from the Module towards the fuse holder. Cut the Wire to length and join the wire to the other half of the fuse holder using a crimp heat shrink connector. Use a heat gun to apply heat to the heat shrink connector to seal the connection.
- Neatly route the Black Wire from the Module to the negative battery terminal on the vehicles main start battery and cut to length. Strip the Black wire and crimp on the heat shrink ring terminal. Use a heat gun to apply heat to the heat shrink ring terminal to seal the connection. Do not undo the nut on the battery terminal unless absolutely necessary, if possible, use the supplied 6mm hex nut to screw onto the thread of the battery terminal and tighten up to the existing nut.

### IMPORTANT INFORMATION:

Run all wiring along the sides of your engine compartment. Be sure to avoid positioning wires too close to hot or moving parts that may melt or pinch the wires. Protect all wiring within the engine bay with split loom. Secure all wiring firmly with cable ties. Existing electrical lines can be used to brace the wiring within the engine bay. Ensure that all wiring connections are crimped and sealed properly using a heat gun to shrink and seal all connections.

## STEP 5

### Test Module Output

- Set the Multimeter to a minimum setting of 500DC Volts.
- Insert the fuse into the fuse holder, DO NOT allow the Blue or White wires to make contact with the Vehicles body.
- Once the modules Green LED is flashing, place the multimeter probe to either the Blue or White wire and then place the other probe to any bare metal surface on the vehicles body. You should get a minimum output of 200DC Volts on your meter. This will confirm that the Green Wire has been correctly earthed to the vehicle, which will allow the system to work effectively when the Capacitive Couplers are attached.
- Remove the fuse and continue to the next step.

## STEP 6

### Wiring the FRONT Capacitive Couplers

- Route the BLUE wire from the module towards the furthest selected Capacitive Coupler site and cut to length, or extend if necessary using 4mm auto wire.
- Make a connection between the BLUE wire (or extended wire) and a Capacitive Coupler using the supplied crimp heat-shrink connector.
- Fit the Capacitive Coupler (Refer to last page for fitting instructions on fitting the Capacitive Coupler).
- Route the WHITE wire from the module towards the nearest selected Capacitive Coupler site and cut to length, or extend if necessary using 4mm auto wire.
- Make a connection between the WHITE wire (or extended wire) and a Capacitive Coupler using the supplied crimp heat-shrink connector.

## STEP 7

### Check Installation

- Check all wiring connections to ensure that they are secure and sealed correctly.
- Ensure that the Capacitive Couplers are all affixed to the body of the vehicle.

## STEP 8

### Insert the fuse

- Insert the fuse into the fuse holder and observe the modules LED's to confirm Normal Operation Mode. (Refer to Modes of Operation below)

## MODES OF OPERATION

The CouplerTec Electronic Rustproofing Module has two LEDs (Red & Green) which indicate the systems current mode of operation.

### The Module has three modes of operation, which are:

#### 1. Start-up Mode

When the fuse is inserted the modules Green LED will illuminate for 30 seconds whilst the system configures itself.

#### 2. Normal Operation Mode

The modules Green LED will flash continuously confirming that the system is functioning correctly.

#### 3. Fault Mode

The modules Red LED will flash upon the detection of a fault. The fault indicators are:

- **Red LED flashing continuously:** This indicates that the module has detected a **Dead Short** and has shut itself down.
- **Red & Green LEDs flashing together 10 times every 50 seconds:** This indicates **Low Battery**, meaning that the vehicles battery level has dropped below the minimum input requirement and that the module has shut itself down to protect the battery.

For more technical information visit: [www.couplertec.com](http://www.couplertec.com) and click on the product information tab.

## FITTING THE CAPACITIVE COUPLER

- Thoroughly clean the site where the Capacitive Coupler is to be located using the alcohol cleaning pad. Remove any oil, wax or dirt. For extremely dirty sites, use white spirits or similar with a rag to clean the site, followed by the use of the alcohol cleaning pad.
- Before affixing the Capacitive Coupler, ensure that all joints between the module and Capacitive Coupler have been completed.
- Once the site is clean and dry. Peel off the backing paper from the back of the Capacitive Coupler ready to secure (don't touch the adhesive surface). The Capacitive Coupler must be affixed in an upright position with the wire facing downwards (refer figure 2), firmly press the Capacitive Coupler onto the prepared site making sure that there are no bubbles under the Capacitive Coupler. The Capacitive Coupler must be 100% in contact with the painted metal surface.

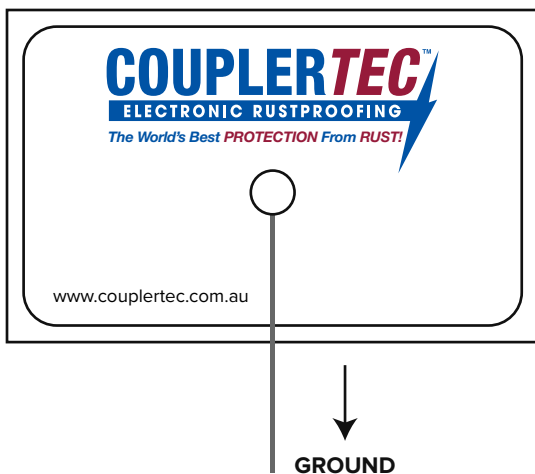

**FIGURE: 2**

**IMPORTANT:** DO NOT install the Capacitive Coupler in an upside down position. Always install the Capacitive Coupler with the wire facing towards the ground.